

# E.T.C

---

## Control Pressure Switch

**CPS 20-61**

**(Threaded)**

## Installation and Maintenance Manual

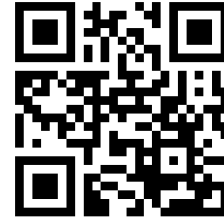

---

### A-General Information and Safety Principles

### B- Installation

### C- Wiring

### D-Maintenance

### E- Device Parts

## A-General Information and Safety

### 1.product overview

Pressure switch type PS-HT1 is used to control the amount of pressure inside the watering and pumping systems, tanks, and pressure lines (for temperatures below 70 ° C).this device is designed for controlling the pressure from 5 Psi to 300 Psi .it is suitable from (-37....66 ° C) for ambient temperate. This equipment is installed with a ¼” gear connection.

### 2. Notes on the device

#### 2.1. Correct operation of the device

The proper operation of the device is guaranteed when some experts according to the principles start to install and set up or repairing.

#### 2.2. Safety principles

Before installing or setting up or repairing be sure about the suitable equipment .please be sure that the selected pressure switch in terms of temperature and pressure is suitable for installing. For selecting in the correct way refer to the technical specification. For improving safety in the places that are in the special situation you can use two devices instead of one.

## B- Installation

Before installation, choose a suitable place in terms of access. This kind of pressure switch is usually mounted vertically on the top of the tank from the gear connection. Please be careful about fixing this device from the brass nut use a suitable wrench. Never use the body part for twisting and closing, Use the wrench to fasten as shown below. This device has a ¼” gear connection.

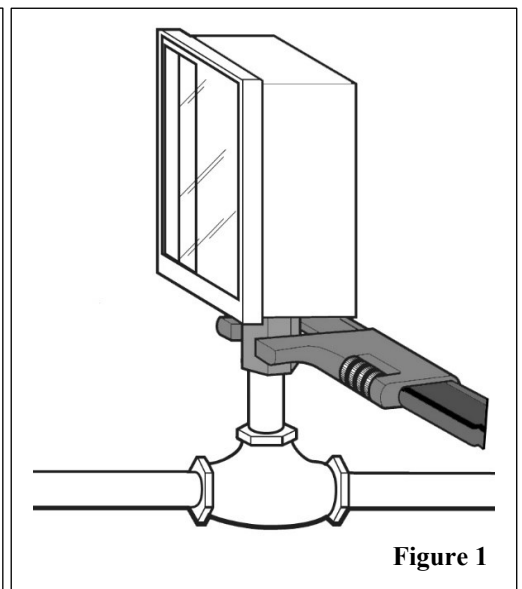
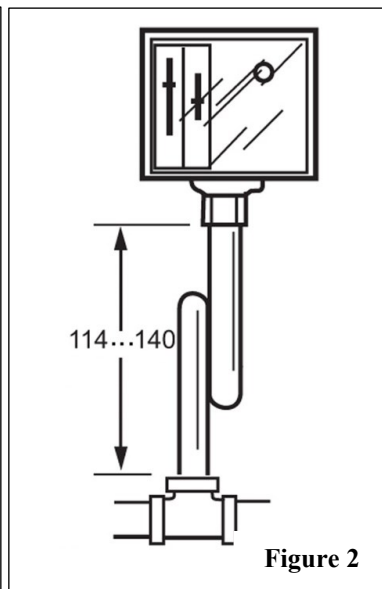
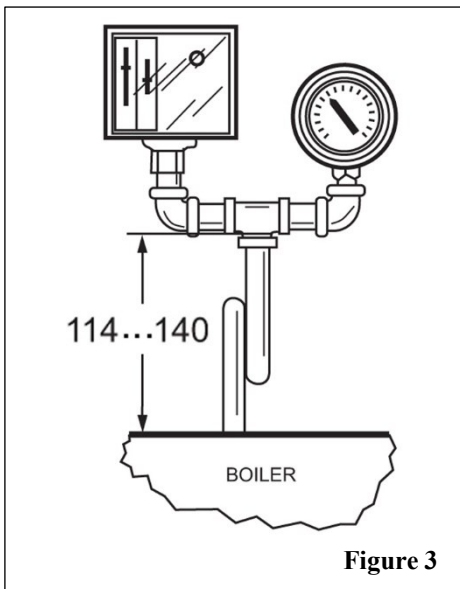

### Warning:

As this equipment is installed in tanks and under pressure systems, so be careful when installing this device pay attention that the amount of the thread sufficiently inserts into the connector, otherwise due to the system pressure, the pressure switch may break away from its location and cause damage. By using the wrench you can fix this device as shown in figure 1.

When you install this equipment be careful about the temperature of the installation place if it is under 110 °C the pressure switch must be installed directly and at the higher temperature, the pressure switch must be installed with a loop to avoid damaging the pressure switch. If the installation has severe vibration, it should be fitted with a flexible (elastic) tube farther away.

## C- Wiring

### 1. Wiring

The following figures illustrate the wiring circuit in three situations. Before starting wiring please disconnect the power supply because of the possibility of electric shock and consequently injury and death.

### 2. Device setting

At the top of the pressure switch, there are two screws. The first screw that shown as number 6 in figure 7 is used to adjust the pressure in the desired range and the second screw as number 8 in figure 7 is used to adjust the difference in pressure desired to return to the initial status.

## D-Maintenance

There is a plastic cover on this device so be careful not to hit it to prevent it from damaging. Use the technical specifications table to avoid the excessive flow of this equipment or don't occur short circuit and to prevent this equipment from being damaged in terms of electrical current, you must use a suitable fuse in the internal current for preventing damage from the microswitch. Also, do not use this equipment above the pressure stated in the technical specifications table, which will damage the diaphragm assembly if you do not comply.

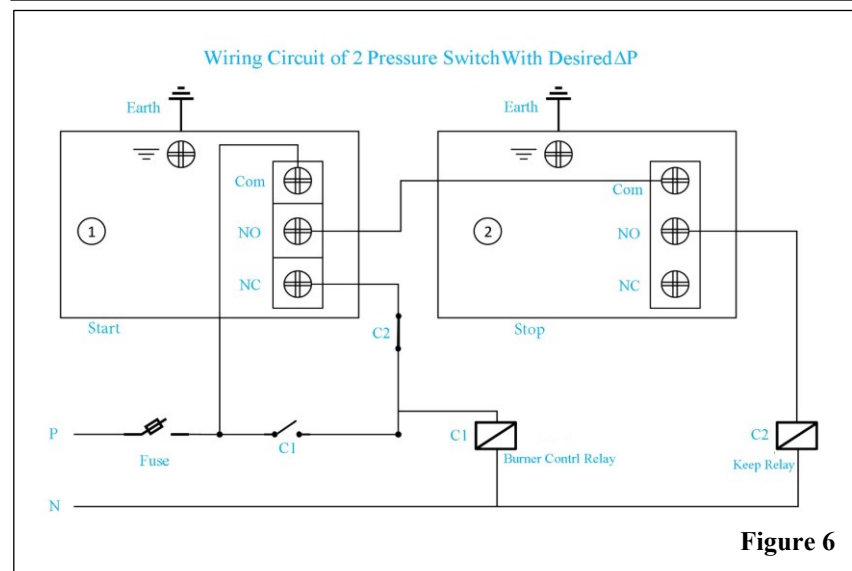
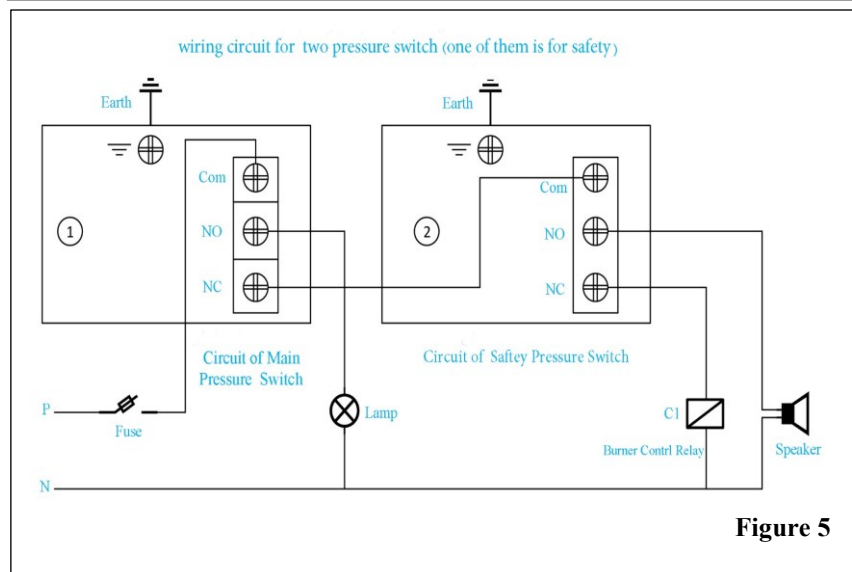
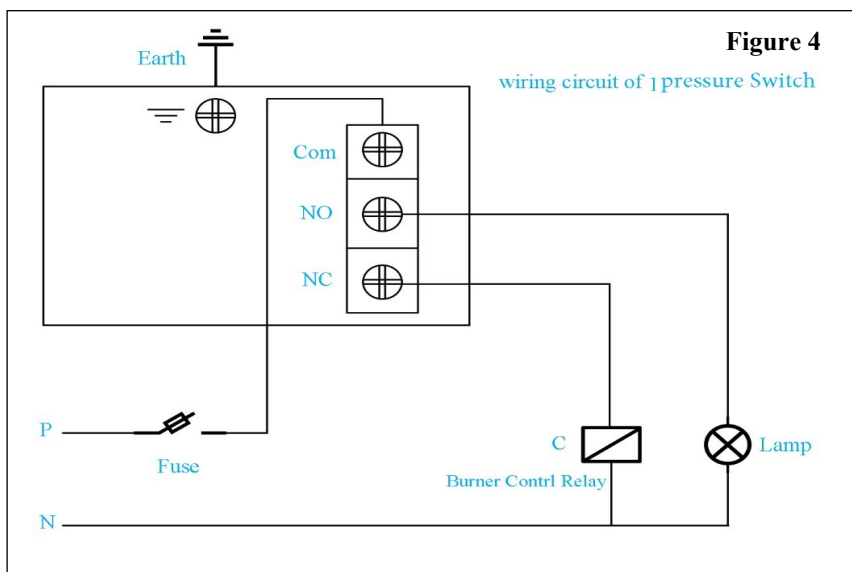

## E- Device Parts

### 1. Technical specification and parts

Max pressure working range	5 ... 50 psi	10 ... 150 psi	20 ... 300 psi
Max. $\Delta P$	6 ... 14 psi	10 ... 22 psi	20 ... 50 psi
Max working temperature without loop	110 °C		
Ingress protection	IP40		
connection type and Material	¼" NPT /MS56		
Body Material	ST37		
Cover Material	Clear Plastic		
Diaphragm Material	SS304		
Switch Type	SPDT		
Switch Capacity	220V AC 15 A		

### 3.Assembly figure:

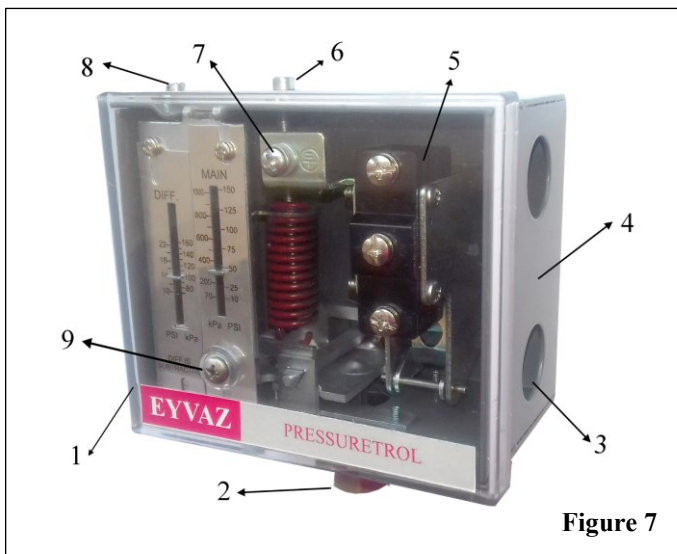

### 2. Parts table:

No	Part Name
1	cover
2	Connection
3	Microswitch cable conduit
4	body
5	Microswitch
6	Pressure adjustment screw
7	Ground screw
8	Differential adjustment screw
9	Cover hold screw

### 4.Spare part table:

Part Number	Part Name
10425	Microswitch
10426	Actuator

[WWW.AZARSAM.CO](http://WWW.AZARSAM.CO)